

100mA Ultra Low Quiescent Current Linear Regulator

Low IQ Regulator

DESCRIPTION

The STL6341 series is a positive voltage regulator with high accuracy output voltage and ultra-low quiescent current which is typically 1.0µA. The device is ideal for battery powered handheld equipments which require low quiescent current.

The STL6341 contains a bandgap voltage reference, an error amplifier, a P-channel pass transistor, and a resistor-divider for setting output voltage. The output voltage is fixed with high accuracy by advanced trimming technology.

The STL6341 has been designed to be used with low cost ceramic capacitors and requires a minimum output capacitor of 1.0µF. The devices are available in SOT-23, SOT-89.

FEATURE

- ◆ Low Current Consumption: 1µA
- ◆ Maximum Output Current: 100mA
- ◆ Low Dropout Voltage: 800mV@50mA
- ◆ Operating Voltage Range: 2.5V to 18V
- ◆ Output Voltage Range: 1.5V to 5.0V
- ◆ Thermal Overload Shutdown Protection
- ◆ Low ESR Capacitor Compatible

APPLICATIONS

- ◆ Battery Powered Equipment.
- ◆ Precision Voltage References
- ◆ Portable Communication Devices
- ◆ Hand Held Electronics
- ◆ Wireless Communication Svstems

PIN CONFIGURATION

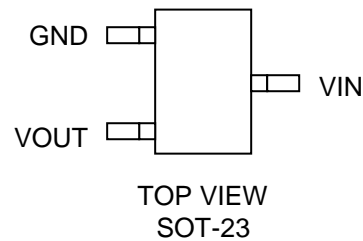
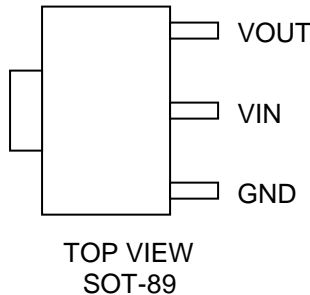

PART MARKING INFORMATION

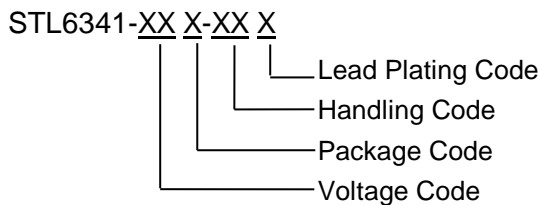

Lead Plating Code

G : Lead-free product.
This product is RoHS compliant

Handling Code

TR : Tape&Reel TB : Tape&Box

Package Code

K : SOT-89 S : SOT-23

Voltage Code

XX : 15 / 18 / 25 / 28 / 30 / 33 / 50

ORDERING INFORMATION

Part Number	SOT-89	Package Code	Package	VOUT Voltage	Shipping
STL6341-XXK-TRG		K	SOT-89	1.5 1.8 2.5 2.8 3.0 3.3 5.0	1000/Tape&Reel
Part Number	SOT-23	Package Code	Package	VOUT Voltage	Shipping
STL6341-XXS-TRG		S	SOT-23	1.5 1.8 2.5 2.8 3.0 3.3 5.0	3000/Tape&Reel

Note:

※ "XX" stands for output voltages.

※ G : Lead-free product. This product is RoHS compliant

ABSOLUTE MAXIMUM RATINGS ($T_A = 25^\circ\text{C}$ Unless otherwise noted)

Parameter	Symbol	Maximum	Unit
Power Dissipation	SOT-89	550	mW
	SOT-23	310	
Input Voltage	V_{IN}	20	V
Output Current Limit	I_{OUT}	100	mA
Operating Ambient Temperature Range	T_{OPR}	-40~+125	$^\circ\text{C}$
Storage Temperature Range	T_{STG}	-55~+150	$^\circ\text{C}$
Lead Soldering Temperature	T_{LEAD}	+260	$^\circ\text{C}$

Note: Exceeding these ratings could cause damage to the device. All voltages are with respect to Ground. Currents are positive into, negative out of the specified terminal.

ELECTRICAL CHARACTERISTICS ($T_A = 25^\circ\text{C}$ Unless otherwise noted)

Parameter	Symbol	Test Conditions	Min	Typ	Max	Unit	
Input Voltage	V_{IN}	-	2.5	-	18	V	
Output Voltage	V_{OUT}	$V_{IN}=V_{OUT}+1\text{V}$, $I_{OUT}=1\text{mA}$ $V_{OUT} \geq 2.7\text{V}$	2%	V_{OUT}	2%	V	
		$V_{IN}=V_{OUT}+1\text{V}$, $I_{OUT}=1\text{mA}$ $V_{OUT} \geq 2.7\text{V}$	2.4%	V_{OUT}	2.4%		
Line Regulation	V_{SR}	$V_{OUT}+1\text{V} \leq V_{IN} \leq 12\text{V}$ $I_{OUT}=1\text{mA}$	-	0.2	0.3	%	
Load Regulation	V_{LR}	$0\text{mA} \leq I_{OUT} \leq 50\text{mA}$ $V_{IN}=V_{OUT}+1\text{V}$	-	0.01	0.02	%	
Dropout Voltage	V_D	$V_{OUT}=5.0\text{V}$,	$I_{OUT}=1\text{mA}$	-	16	20	mV
			$I_{OUT}=10\text{mA}$	-	160	200	mV
			$I_{OUT}=50\text{mA}$	-	800	1000	mV
Maximum Load Current	I_{MAX}		50		-	mA	
Quiescent Current	I_Q	$V_{IN}=V_{OUT}+1\text{V}$	-	1.0	2.5	μA	
Temperature Characteristic of ΔV_{OUT}	$\frac{\Delta V_{OUT}}{\Delta T_A}$	$V_{OUT}=5.0\text{V}$, $I_{OUT}=10\text{mA}$ $T_A=-40^\circ\text{C} \sim +150^\circ\text{C}$	-	0.6	-	$\text{mV}/^\circ\text{C}$	

NOTES: (1) Measured using a double sided board with 1 x 2 square inches of copper area connected to the GND pin for "heat spreading.

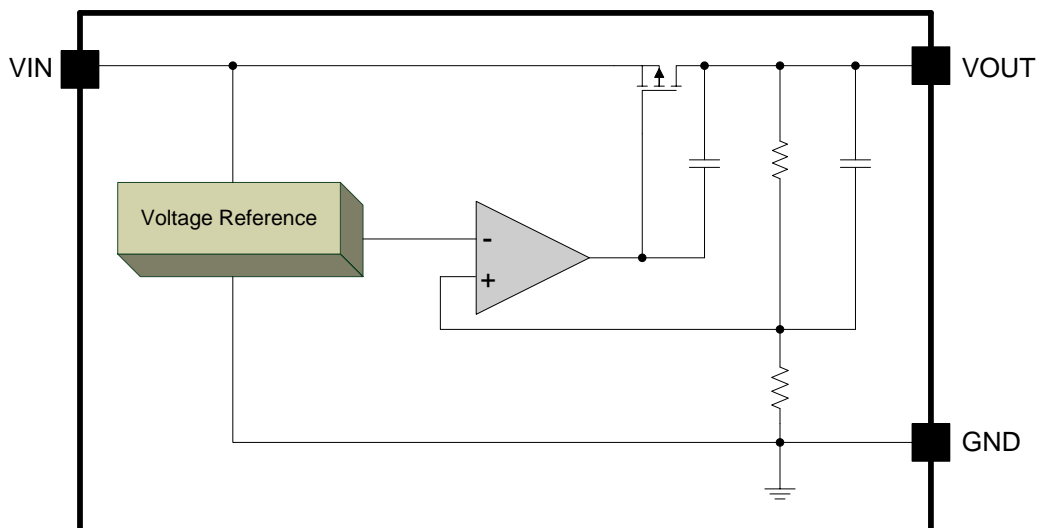
FUNCTION BLOCK DIAGRAM

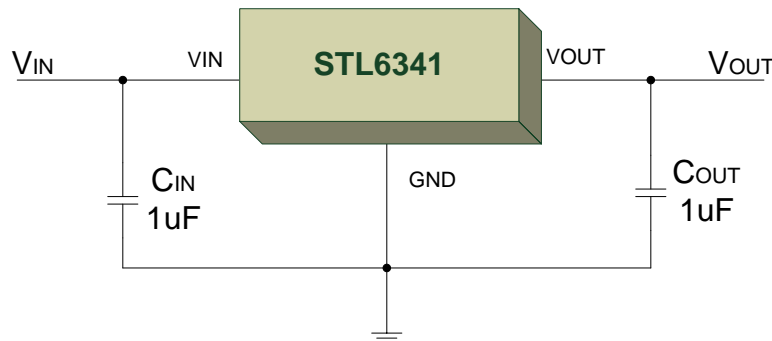
■ TYPICAL APPLICATIONS

■ APPLICATION INFORMATION
◆ Detail Description

The STL6341 is a low quiescent current LDO linear regulator. It supplies a preset 3.3V, 3.6V and 5.0V output voltages for output current up to 50mA. Other mask options for special output voltages from 1.5V to 5.0V with 100mV increment are also available. As illustrated in function block diagram, it consists of a 1.23V band gap reference, error amplifier, P-channel pass transistor and an internal feedback voltage divider.

The 1.23V band gap reference is connected to the error amplifier, which compares this reference with the feedback voltage and amplifies the voltage difference. If the feedback voltage is lower than the reference voltage, the pass-transistor gate is pulled lower, which allows more current to pass to the output pin and increases the output voltage. If the feedback voltage is too high, the pass-transistor gate is pulled up to decrease the output voltage.

The output voltage is feedback through an internal resistor-divider connected to OUT. Additional blocks include an output current limiter, thermal sensor, and shutdown logic.

◆ Internal P-channel Pass Transistor

The STL6341 features a P-channel MOSFET pass transistor. Unlike similar designs using PNP pass transistors, P-channel MOSFETs require no base drive, which reduces ground pin current. PNPbased regulators also waste considerable current in dropout conditions when the pass transistor saturates, and use high base-drive currents under large loads. The STL6341 does not

suffer from these problems and consumes only 1.0µA (Typ.) of ground pin current under heavy loads as well as in dropout conditions.

◆ Output Voltage Selection

The first two digits of part number suffix identify the output voltage (see Ordering Information). For example, the STL6341-50 has a preset 5.0V output voltage.

◆ Input-Output Voltage

A regulator's minimum input-output voltage differential, or dropout voltage, determines the lowest usable supply voltage. In battery-powered systems, this will determine the useful end-of-life battery voltage. The STL6341 uses a P-channel MOSFET pass transistor, its dropout voltage is a function of drain-to-source on-resistance ($R_{DS(ON)}$) multiplied by the load current.

$$V_{DROPOUT} = V_{IN} - V_{OUT} = R_{DS(ON)} \times I_{OUT}$$

APPLICATION CIRCUITS

◆Current Boost Circuit

The figure below shows a boost circuit for increasing the output current. Output current 60mA or more can be obtained by this circuit.

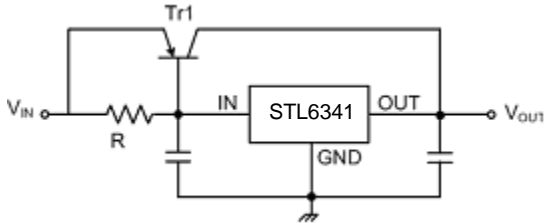

Short-Circuit protection of Tr1 can be implemented by adding the sense resistor R_S and the PNP transistor Tr2 as shown below.

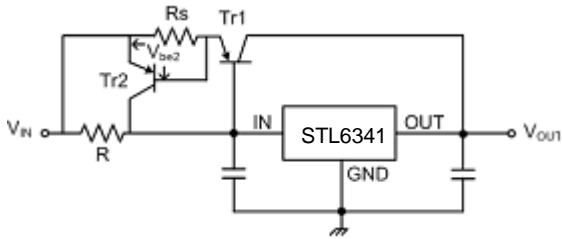

The current limit of the protection circuit is:

$$I_{LIMIT} = V_{BE2} / R_S$$

◆Voltage Boost Circuit

If the output voltage you need is greater than 5.0V, the circuit in the figure below will increase output voltages easily.

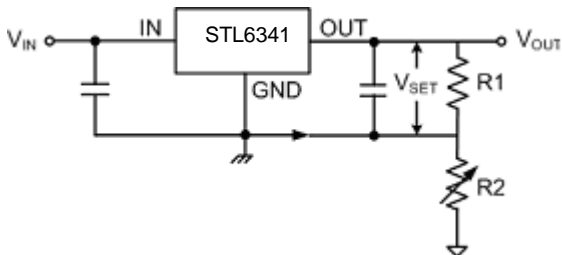

The output voltage is obtained by:

$$V_{OUT} = V_{SET} \times (1 + R_2/R_1) + I_{SS} \times R_2$$

Where V_{SET} is the preset output voltage of STL6341 and I_{SS} is the quiescent current. Because of the low quiescent current, the resistor values, R_1 and R_2 , can be set as large as several hundreds k Ω to lower the power consumption of the whole system.

◆Constant Current Source

The STL6341 Series can be used as a constant current source within allowable current limit.

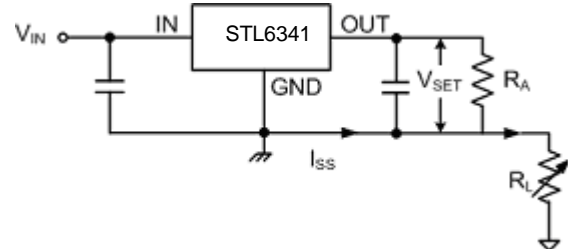

The output current is obtained by:

$$I_{OUT} = V_{SET} / R_A + I_{SS}$$

◆Dual Supply

A dual supply can be constructed with two STL6341 series as show in the figure below. This circuit provides two outputs (5V and 8V) with the STL6341 -30 and the STL6341-50. As the resistance R lets the quiescent current of IC1 pass. R is unnecessary if the minimum output current of IC2 is more than the IC1 quiescent current. D is a protection diode in case V_{OUT2} becomes larger than V_{OUT1} .

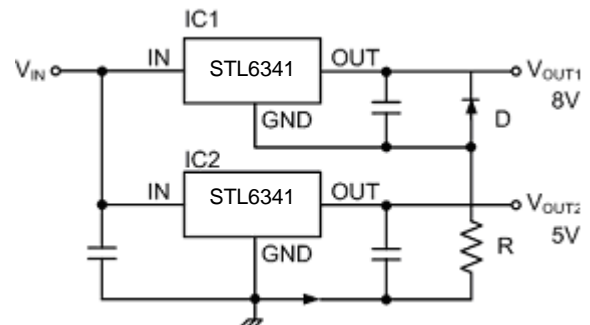

TYPICAL CHARACTERISTICS (25°C Unless Note)

Output Voltage VS Input Voltage

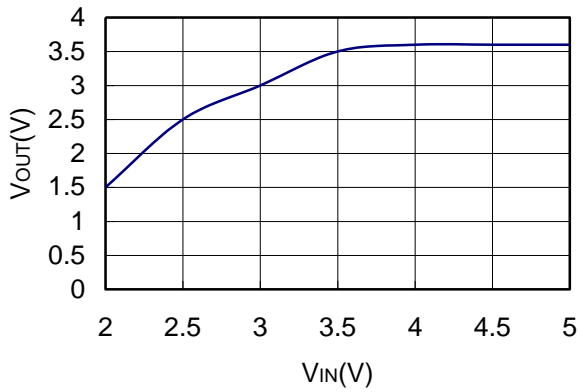

GND Pin Current VS Input Voltage

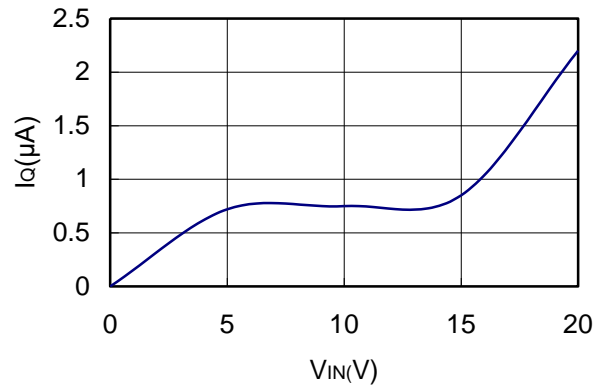

Output Voltage VS Temperature

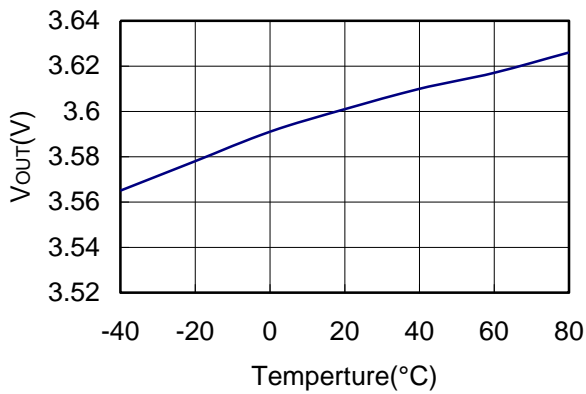

GND Pin Current VS Temperature

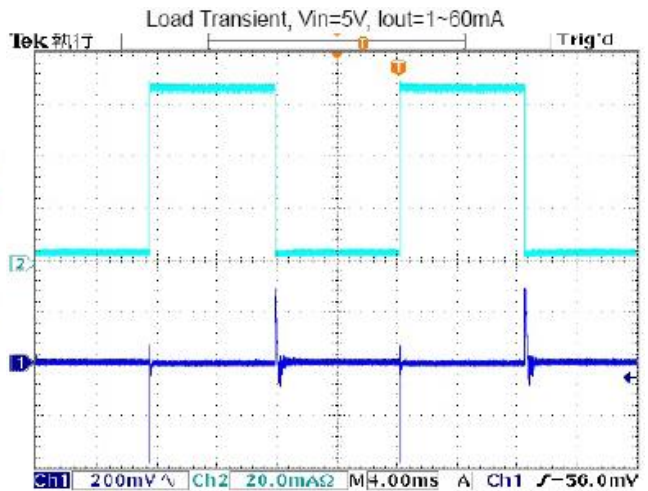
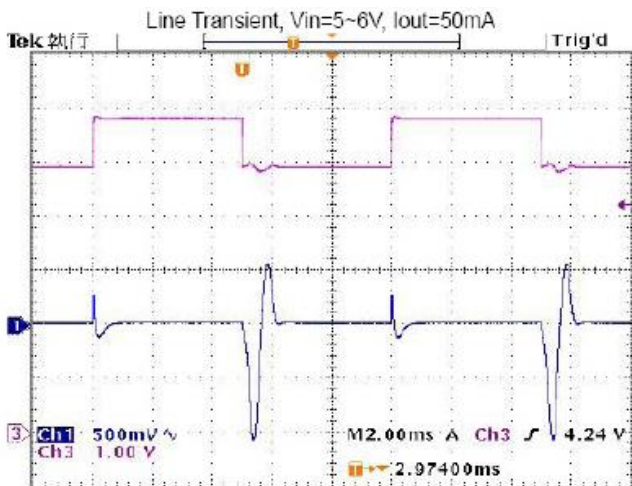
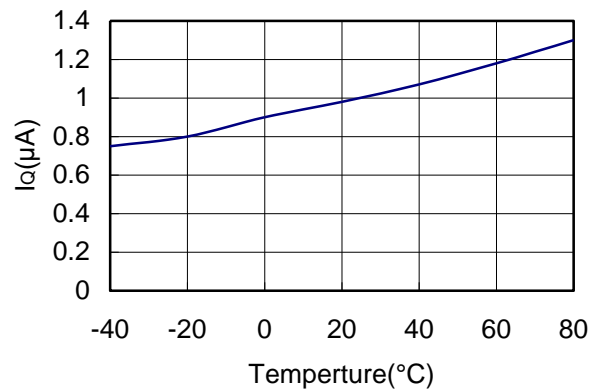

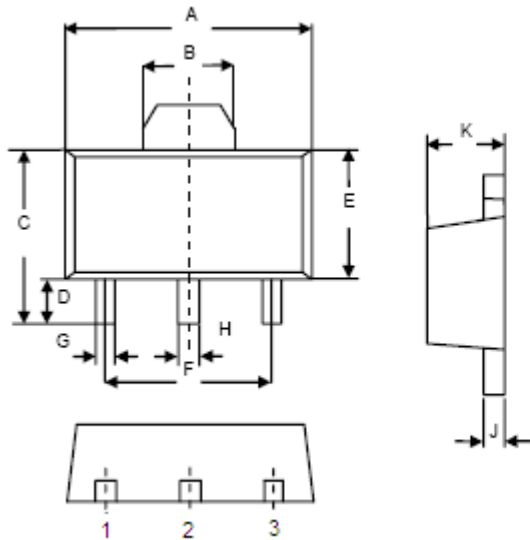
■ SOT-89 PACKAGE DIMENSIONS

Symbol	Dimensions			
	Inches		Millimeters	
	Min	Max	Min	Max
A	.173	.181	4.40	4.60
B	.055	.071	1.40	1.80
C	.154	.165	3.91	4.19
D	.035	.043	0.90	1.10
E	.091	.102	2.3	2.6
F	.114	.122	2.90	3.10
G	.013	.020	0.32	0.52
H	.014	.022	0.36	0.56
J	.014	.017	0.35	0.44
K	.055	.063	1.40	1.60

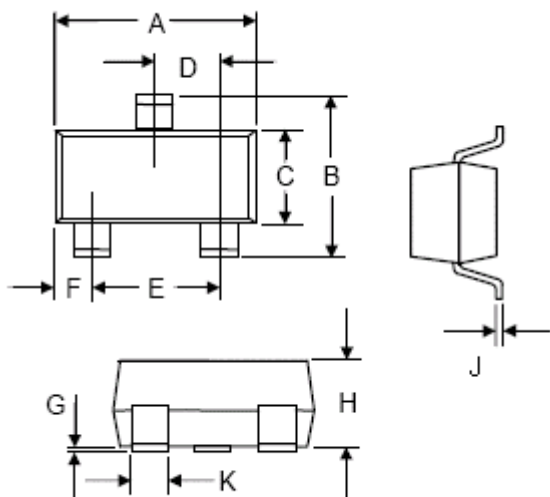
■ SOT-23 PACKAGE DIMENSIONS

Symbol	Dimensions			
	Inches		Millimeters	
	Min	Max	Min	Max
A	0.110	0.118	2.80	3.00
B	0.83	0.098	2.60	3.00
C	0.059	0.067	1.50	1.70
D	0.35	0.041	0.89	1.03
E	0.70	0.081	1.78	2.05
F	0.18	0.024	0.45	0.60
G	0.000	0.004	0.000	0.100
H	0.035	0.047	1.00	1.20
J	0.002	0.008	0.047	0.207
K	0.012	0.02	0.30	0.50